

Series TG32 Toe Space Grille

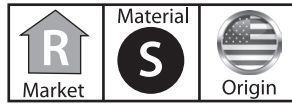

Residential
Floor & Baseboard

- Steel construction
- Rolled face
- With mounting holes
- 2 1/4" and 4" lengths, 10", 12", 14" widths
- Golden Brown or White finish
- Made in the U.S.A.

Dimensional Drawings

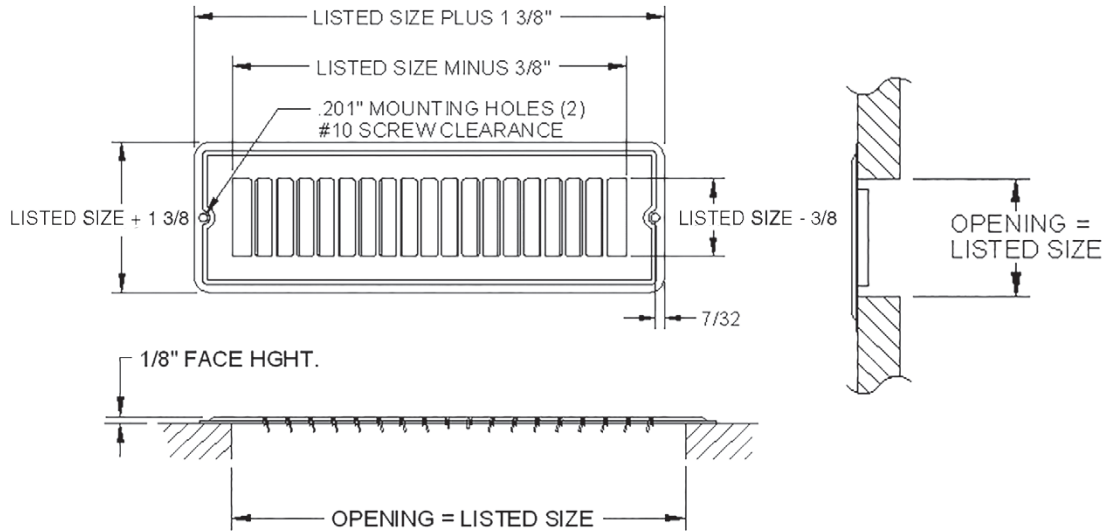

Performance Data, Series TG32

Unit Size (in.)	Overall Size (in.)	Face Velocity	300	400	500	600	700	800	900	1000
		Pressure Loss	.006	.010	.016	.022	.031	.040	.050	.062
2 1/4 x 10 Ak .097	3 5/8 x 11 3/8	Cfm	29	38	48	58	68	77	87	97
		Throw	2	3	3.5	4	4.5	5	6	6.5
		Spread	3.5	4.5	5	6.5	7.5	8.5	10	11
2 1/4 x 12 Ak .118	3 5/8 x 13 3/8	Cfm	35	47	59	70	82	94	106	118
		Throw	2	3	3.5	4	4.5	5.5	6	7
		Spread	3.5	5	5	7	8	10	11	12
2 1/4 x 14 Ak .132	3 5/8 x 15 3/8	Cfm	39	52	65	79	92	105	118	131
		Throw	2.5	3	3.5	4.5	5	6	6.5	7.5
		Spread	3.5	4.5	6	7	8.5	10	11.5	12.5
4 x 10 Ak .174	5 3/8 x 11 3/8	Cfm	52	69	86	104	121	138	156	173
		Throw	2.5	3	4	4.5	5.5	6.5	7	8
		Spread	4	4.5	6.5	8.5	9.5	11	12.5	14
4 x 12 Ak .208	5 3/8 x 13 3/8	Cfm	62	83	104	124	145	166	187	208
		Throw	2.5	3.5	4	5.5	6	7	8	8.5
		Spread	4	6	7.5	9	10.5	12	13.5	15.5
4 x 14 Ak .243	5 3/8 x 15 3/8	Cfm	72	97	121	145	170	194	218	243
		Throw	3	4	5	6	7	7.5	8.5	9.5
		Spread	4.5	6.5	8.5	9.5	11.5	13	14	16.5

Terminal velocity is 50 fpm. Always specify width by height.