

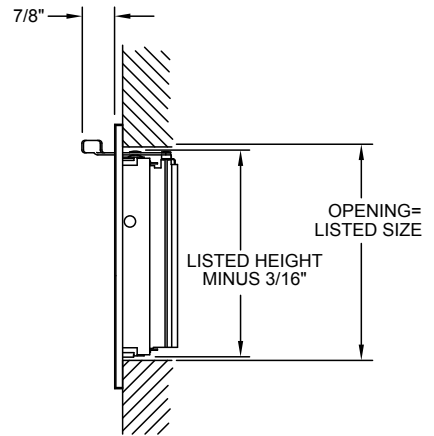

Continental Industries, Inc.  
 100 West Windsor Avenue  
 Elkhart, Indiana 46514  
 Phone: 800.735.5272 • Fax: 574.262.2075  
 Email: info@continentalindustries.com  
 Web: www.continentalindustries.com

# Submittal Drawing & Form

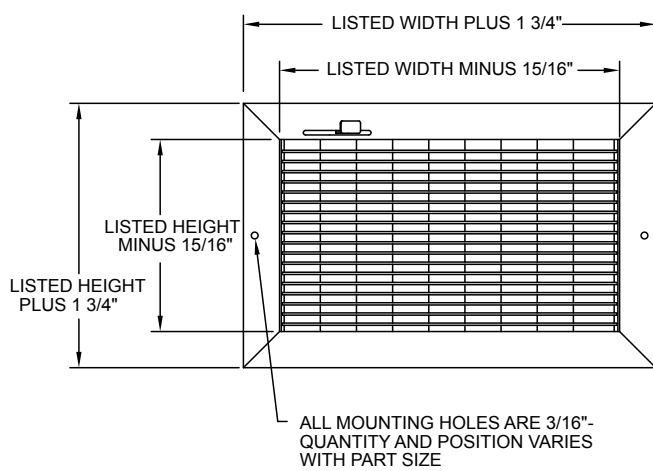

DAMPERS SHOWN OPEN, ALL VIEWS

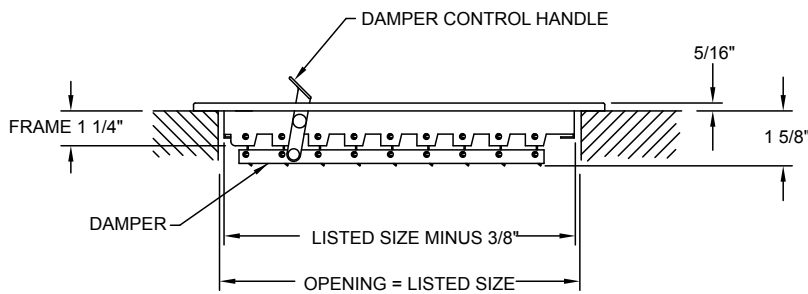

- Description**
- Adjustable, Horizontal Roll-Form Face Bars
  - 3/4" Spacing for Easy Adjustment
  - Single Deflection
  - Multi-Shutter Damper
  - Steel Construction
  - White finish

<b>Project Details</b>	<b>Submitted by:</b>	<b>RHML Series</b> <b>RHML</b>
Job Title:		
Location:		
Architect:		
Engineer:		
Contractor:	<b>Date:</b>	<b>SD-RHML-01</b>