

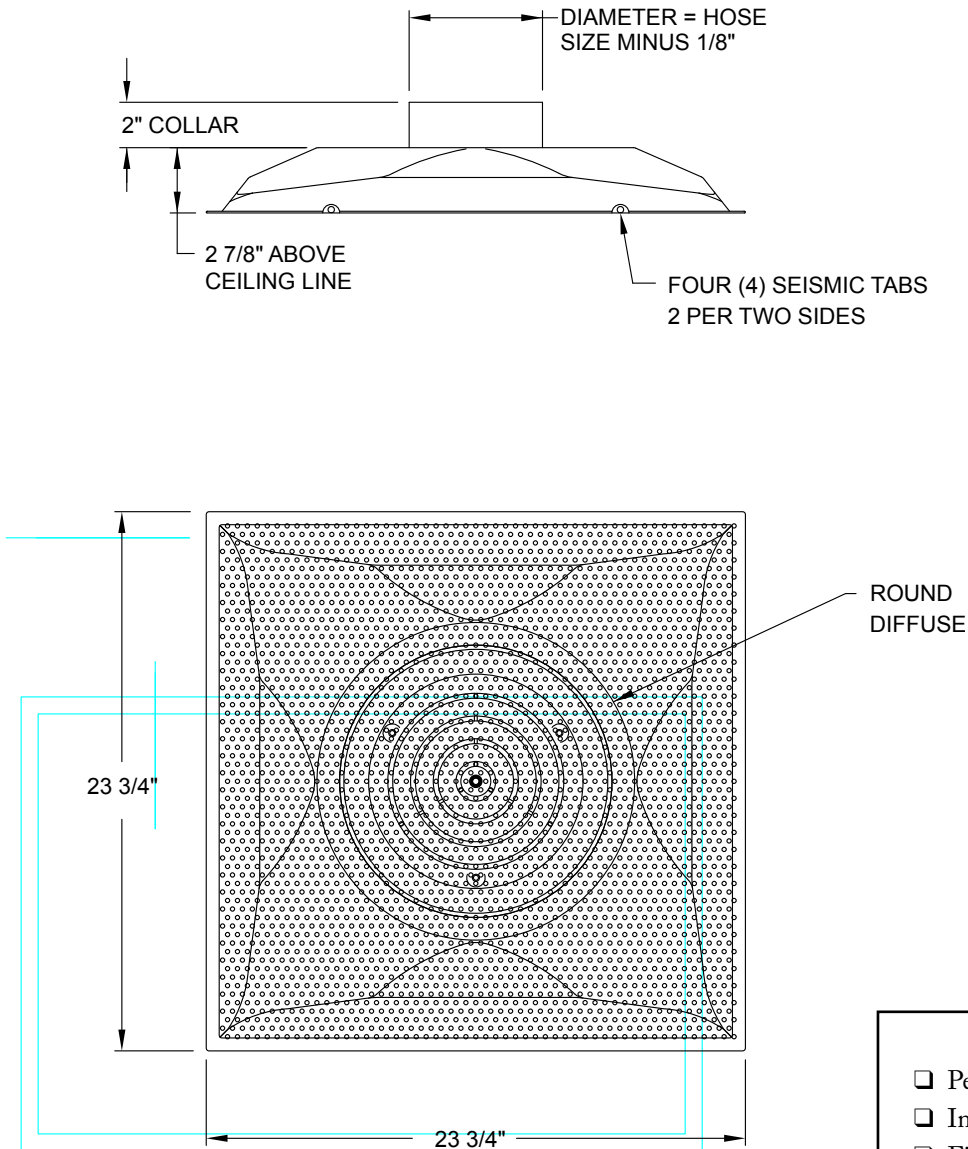

Continental Industries, Inc.
 100 West Windsor Avenue
 Elkhart, Indiana 46514
 Phone: 800.735.5272 • Fax: 574.262.2075
 Email: info@continentalindustries.com
 Web: www.continentalindustries.com

Submittal Drawing & Form



- | Description |
|--|
| <input type="checkbox"/> Perforated Face |
| <input type="checkbox"/> Installed Round Damper |
| <input type="checkbox"/> Fixed Collar of 6", 8", 10", 12" or 14" |
| <input type="checkbox"/> No Insulation |
| <input type="checkbox"/> White finish |

Project Details	Submitted by:	6900 Series T-Bar (Lay-In)
Job Title:		
Location:		
Architect:		
Engineer:		
Contractor:	Date:	SD-6900-01