

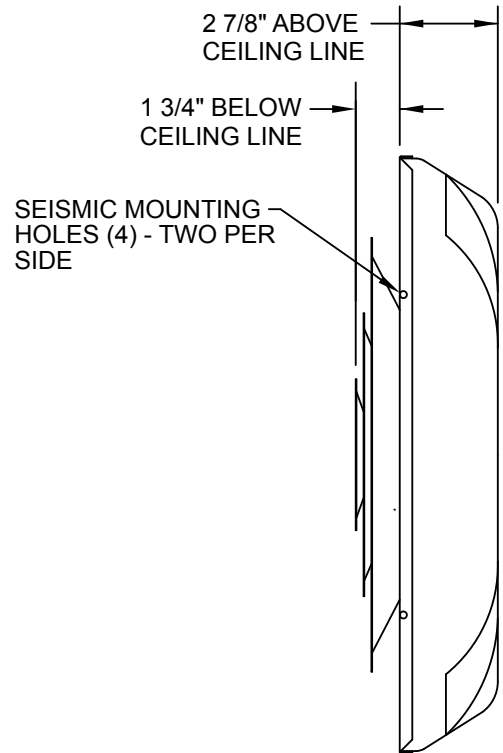

Continental Industries, Inc.
 100 West Windsor Avenue
 Elkhart, Indiana 46514
 Phone: 800.735.5272 • Fax: 574.262.2075
 Email: info@continentalindustries.com
 Web: www.continentalindustries.com

Submittal Drawing & Form

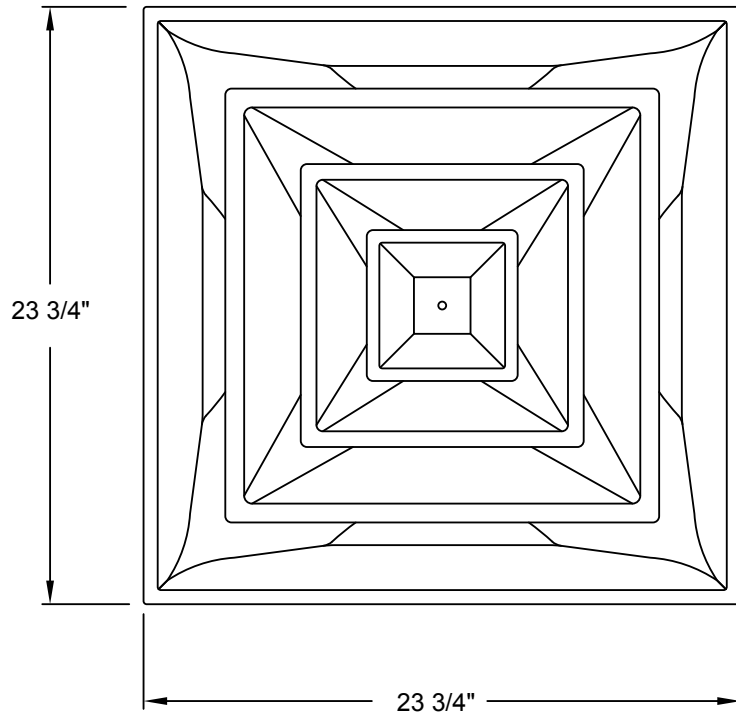

MOLDED R6 PLENUM (PRESCORED)
 CUT TO FIT COLLAR, 6", 8", 10", 12" & 14"

Description
<input type="checkbox"/> High volume air delivery
<input type="checkbox"/> 360° diffusion
<input type="checkbox"/> 3-cone, drop-down design
<input type="checkbox"/> Heavy gauge steel plenum
<input type="checkbox"/> Integrated R6 formed plenum
<input type="checkbox"/> No collar
<input type="checkbox"/> Seismic tabs
<input type="checkbox"/> White electrocoat finish

Project Details	Submitted by:	BHV P6 Series T-Bar (lay-in) Diffuser
Job Title:	Date:	
Location:		
Architect:		
Engineer:		
Contractor:		
		SD-BHVP6-01