

Series DBH T-bar Diffuser

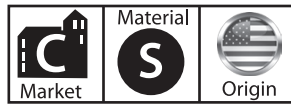

- A design alternative to our standard Series BHV diffuser
- Steel construction
- 3-tier diffusion, 360° pattern
- Fixed collar and no collar models
- No insulation
- White finish
- Made in the U.S.A.



Associated Series:

Series DBH P6

- DBH + R6-rated fiberglass plenum

Series DBH D

- DBH + installed Series 3800 damper

Dimensional Drawing

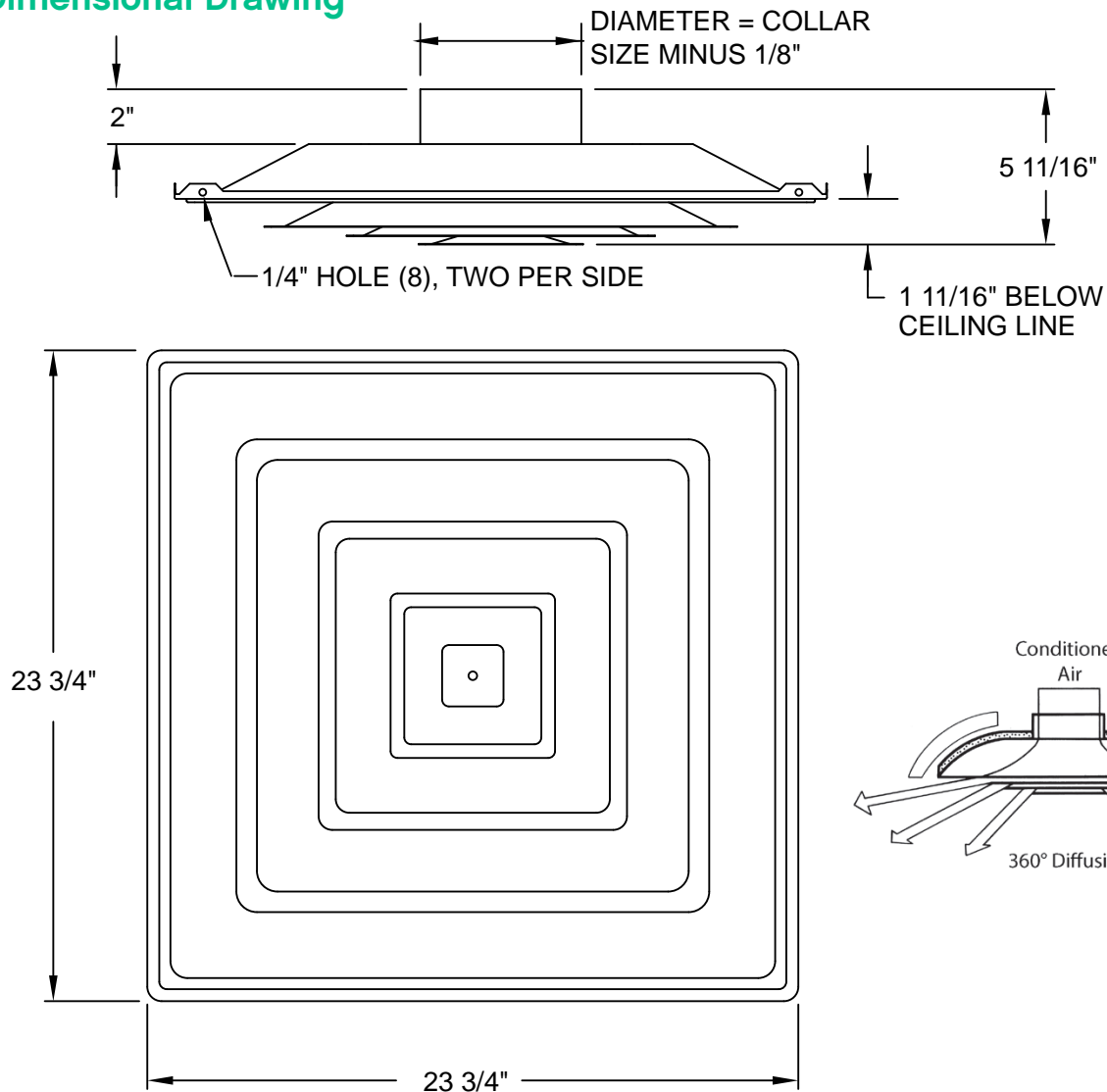

Commercial
T-bar (lay-in)

Performance Data, Series DBH

Collar Size	Neck Velocity	400	500	600	700	800	900	1000	1200	1400	1600
6" An .20 Ak .78	Cfm	80	100	120	135	155	175	195	240	280	320
	Ps	0.01	0.02	0.02	0.03	0.04	0.05	0.06	0.09	0.12	0.15
	Nc	<20	<20	<20	<20	20	20	25	30	35	40
	Throw	3	4	4	5	6	6	7	8	10	11
7" An .27 Ak .81	Cfm	110	135	160	190	220	240	270	320	380	420
	Ps	0.01	0.02	0.03	0.03	0.05	0.06	0.07	0.10	0.14	0.18
	Nc	<20	<20	<20	<20	20	20	25	30	35	40
	Throw	4	6	6	7	8	10	11	12	14	17
8" An .35 Ak .92	Cfm	140	175	210	250	280	320	350	420	490	560
	Ps	0.01	0.02	0.03	0.04	0.05	0.07	0.08	0.12	0.16	0.21
	Nc	<20	<20	<20	20	20	25	30	35	35	40
	Throw	5	6	8	9	10	11	12	14	17	20
9" An .44 Ak 1.20	Cfm	180	220	270	310	350	390	440	530	610	700
	Ps	0.02	0.02	0.04	0.05	0.06	0.08	0.10	0.14	0.20	0.25
	Nc	<20	<20	<20	20	20	25	30	35	40	45
	Throw	6	8	9	11	13	14	17	20	23	26
10" An .54 Ak 1.20	Cfm	220	270	330	380	440	490	550	660	770	870
	Ps	0.02	0.03	0.04	0.06	0.07	0.09	0.12	0.17	0.23	0.29
	Nc	<20	<20	20	20	25	30	35	35	40	45
	Throw	8	10	12	14	15	17	19	23	27	30
12" An .78 Ak 1.65	Cfm	320	390	470	550	630	710	790	940	1100	1260
	Ps	0.02	0.03	0.05	0.06	0.08	0.10	0.13	0.18	0.25	0.32
	Nc	<20	20	20	25	30	35	35	40	45	45
	Throw	8	10	12	14	17	19	21	25	29	33
14" An 1.07 Ak 2.06	Cfm	430	540	640	750	860	960	1075	1275	1500	1700
	Ps	0.03	0.05	0.07	0.10	0.13	0.16	0.19	0.28	0.38	0.48
	Nc	<20	20	20	25	30	35	40	40	45	45
	Throw	9	11	13	16	18	20	22	26	31	34

Terminal velocity: 75 fpm

An = Neck (collar) Area. Measured in square feet.

Ak = Effective Area. The calculated area of the outlet based on average, measured velocity between fins. Measured in square feet.

Neck Velocity = Velocity of air flow through the nominal area of the duct connection to the diffuser assembly. Measured in feet per minute.

Cfm = Air Flow Rate. Volume of air moving past a given plane per unit of time. Measured in cubic feet per minute.

Ps = Static Pressure. The normal outward force of air within a duct. Measured in inches of water.

Nc = Discharge acoustical noise, based on 10 dB room absorption. Measured to the nearest 1.0 dB.

Throw = Distance the air stream travels from the outlet to a point where terminal velocity is reached. Measured in feet.