

# Series FBG60/AFBG60

## Fixed Bar Grille

- Designed for Supply or Return Air usage
- Fixed, horizontal, roll-form face bars
- Bars fixed at 60° deflection
- Commercial grade steel construction (FBG60)
- Commercial grade **aluminum** construction (AFBG60)
- White finish
- Made in the U.S.A.

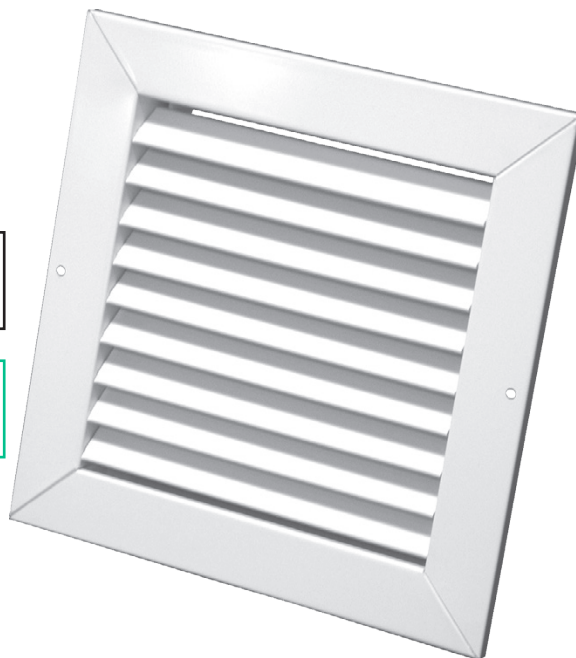
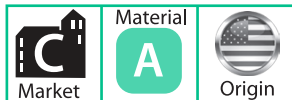

## Dimensional Drawings

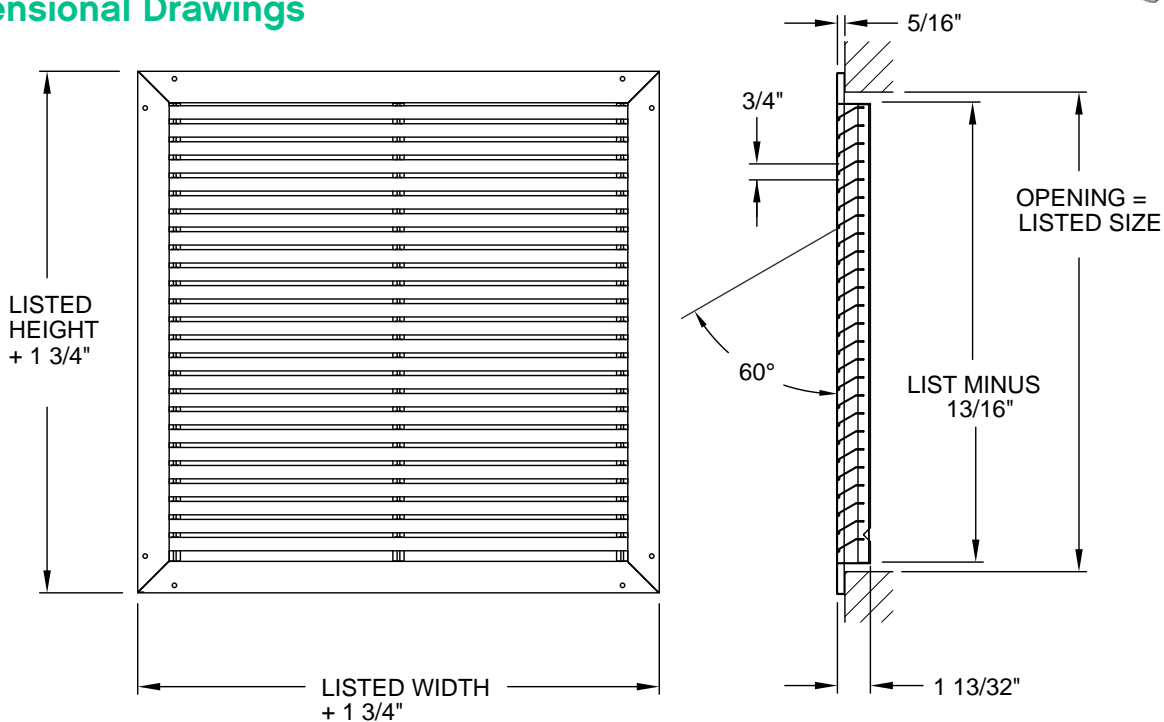

## Performance Data, Series FBG60/AFBG60

Unit Size (in.)	Overall Size (in.)	Face Velocity	400	600	800	1000
6 x 6 Ak .00	7 <sup>3</sup> / <sub>4</sub> x 7 <sup>3</sup> / <sub>4</sub>	Cfm	35	53	71	89
		Pt	0.005	0.025	0.027	0.068
8 x 8 Ak .20	9 <sup>3</sup> / <sub>4</sub> x 9 <sup>3</sup> / <sub>4</sub>	Cfm	78	117	156	195
		Pt	0.006	0.026	0.028	0.069
10 x 6 Ak .17	11 <sup>3</sup> / <sub>4</sub> x 7 <sup>3</sup> / <sub>4</sub>	Cfm	69	103	138	172
		Pt	0.006	0.025	0.027	0.068
10 x 10 Ak .34	11 <sup>3</sup> / <sub>4</sub> x 11 <sup>3</sup> / <sub>4</sub>	Cfm	138	206	275	344
		Pt	0.008	0.026	0.028	0.069
12 x 6 Ak .21	13 <sup>3</sup> / <sub>4</sub> x 7 <sup>3</sup> / <sub>4</sub>	Cfm	85	128	171	214
		Pt	0.011	0.026	0.046	0.075

**Performance Data, Series FBG60/AFBG60 (continued)**

Unit Size (in.)	Overall Size (in.)	Face Velocity	400	600	800	1000
12 x 8 Ak .32	13 <sup>3</sup> / <sub>4</sub> x 9 <sup>3</sup> / <sub>4</sub>	Cfm	128	192	256	320
		Pt	0.014	0.025	0.027	0.068
12 x 12 Ak .50	13 <sup>3</sup> / <sub>4</sub> x 13 <sup>3</sup> / <sub>4</sub>	Cfm	199	299	399	498
		Pt	0.009	0.038	0.040	0.109
14 x 6 Ak .26	15 <sup>3</sup> / <sub>4</sub> x 7 <sup>3</sup> / <sub>4</sub>	Cfm	102	153	204	255
		Pt	0.011	0.041	0.045	0.114
14 x 8 Ak .38	15 <sup>3</sup> / <sub>4</sub> x 9 <sup>3</sup> / <sub>4</sub>	Cfm	153	230	306	383
		Pt	0.010	0.039	0.042	0.109
14 x 14 Ak .72	15 <sup>3</sup> / <sub>4</sub> x 15 <sup>3</sup> / <sub>4</sub>	Cfm	289	434	578	723
		Pt	0.010	0.039	0.042	0.083
16 x 10 Ak .59	17 <sup>3</sup> / <sub>4</sub> x 11 <sup>3</sup> / <sub>4</sub>	Cfm	238	356	475	594
		Pt	0.015	0.026	0.028	0.069
16 x 16 Ak .99	17 <sup>3</sup> / <sub>4</sub> x 17 <sup>3</sup> / <sub>4</sub>	Cfm	396	594	792	990
		Pt	0.011	0.041	0.045	0.086
18 x 18 Ak .85	19 <sup>3</sup> / <sub>4</sub> x 19 <sup>3</sup> / <sub>4</sub>	Cfm	482	723	964	1205
		Pt	0.007	0.034	0.033	0.052
20 x 10 Ak .74	21 <sup>3</sup> / <sub>4</sub> x 11 <sup>3</sup> / <sub>4</sub>	Cfm	296	445	593	741
		Pt	0.015	0.026	0.028	0.069
20 x 12 Ak .86	21 <sup>3</sup> / <sub>4</sub> x 13 <sup>3</sup> / <sub>4</sub>	Cfm	346	519	691	864
		Pt	0.016	0.027	0.029	0.070
20 x 14 Ak 1.05	21 <sup>3</sup> / <sub>4</sub> x 15 <sup>3</sup> / <sub>4</sub>	Cfm	420	630	840	1050
		Pt	0.012	0.040	0.041	0.082
20 x 20 Ak 1.54	21 <sup>3</sup> / <sub>4</sub> x 21 <sup>3</sup> / <sub>4</sub>	Cfm	617	926	1235	1543
		Pt	0.014	0.033	0.030	0.050
24 x 10 Ak .91	25 <sup>3</sup> / <sub>4</sub> x 11 <sup>3</sup> / <sub>4</sub>	Cfm	363	545	726	908
		Pt	0.016	0.027	0.029	0.070
24 x 12 Ak 1.06	25 <sup>3</sup> / <sub>4</sub> x 13 <sup>3</sup> / <sub>4</sub>	Cfm	424	635	847	1059
		Pt	0.009	0.038	0.041	0.082
24 x 14 Ak 1.29	25 <sup>3</sup> / <sub>4</sub> x 15 <sup>3</sup> / <sub>4</sub>	Cfm	514	771	1029	1286
		Pt	0.018	0.029	0.031	0.072
24 x 24 Ak 2.27	25 <sup>3</sup> / <sub>4</sub> x 25 <sup>3</sup> / <sub>4</sub>	Cfm	908	1361	1815	2269
		Pt	0.007	0.039	0.042	0.046
30 x 10 Ak 1.16	31 <sup>3</sup> / <sub>4</sub> x 11 <sup>3</sup> / <sub>4</sub>	Cfm	463	695	926	1158
		Pt	0.018	0.029	0.031	0.072
30 x 12 Ak 1.35	31 <sup>3</sup> / <sub>4</sub> x 12 <sup>3</sup> / <sub>4</sub>	Cfm	540	810	1080	1350
		Pt	0.026	0.034	0.032	0.095
30 x 14 Ak 1.64	31 <sup>3</sup> / <sub>4</sub> x 15 <sup>3</sup> / <sub>4</sub>	Cfm	656	984	1312	1640
		Pt	0.027	0.034	0.033	0.074
30 x 20 Ak 2.41	31 <sup>3</sup> / <sub>4</sub> x 21 <sup>3</sup> / <sub>4</sub>	Cfm	965	1447	1929	2411
		Pt	0.029	0.035	0.037	0.078

Commercial  
Sidewall or Ceiling

# Mounting Hole Guide for Select Products

The following products in this section have embossed (recessed) mounting holes.

Series	Page #
RVML & AVM	122, 127
RHML & AHM	129, 131
RGV & ARGV	133
RGV-0 & ARVG-0	135
RGH & ARGH	137
RGH-0 & ARGH-0	139
HVG & AHVG	141
VHG & AVHG	143
FBG40 & AFBG40	145
FBG60 & AFBG60	147

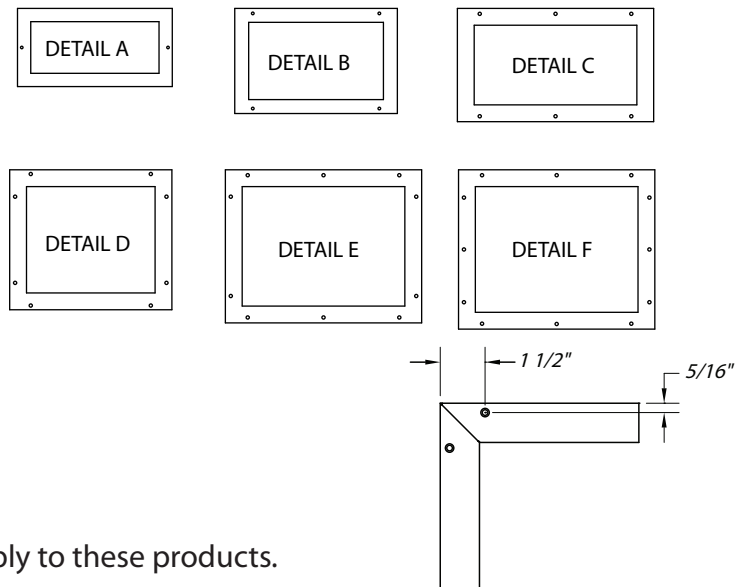

The following chart and diagrams above apply to these products.

		Width																									
		6	8	10	12	14	15	16	18	20	22	24	26	28	30	32	34	36	38	40	42	44	46	48			
Height	4																									4	
	6																										6
	8				A							B															8
	10			2 Holes							4 Holes									C							10
	12																				6 Holes						12
	14																										14
	15																										15
	16																										16
	18																										18
	20																										20
	22			B								D									E						22
	24			4 Holes								8 Holes									10 Holes						24
	26																										26
	28																										28
	30																										30
	32																										32
	34																										34
	36																										36
38			C								E									F						38	
40			6 Holes								10 Holes									12 Holes						40	
42																										42	
44																										44	
46																										46	
48																										48	
		6	8	10	12	14	15	16	18	20	22	24	26	28	30	32	34	36	38	40	42	44	46	48			
		Width																									

Commercial Sidewall or Ceiling