

AIRJET®

gas venting systems

residential/
industrial/
commercial



Air-Jet Gas Vent
is listed by
Underwriters
Laboratories,
Standard
UL-441,
and accepted
by FHA, VA,
BOCA, ICBO and SBC



Gas venting systems

Superior gas venting for every installation

Engineered design gives you more features for fast assembly, long-lasting service—top performance in Type "B" gas venting systems for all applications.

Field service

Our complete network of representatives and distributors is your insurance of a quick response to venting questions. Solutions to your venting problems are nearby and readily available from highly-trained and experienced Air-Jet representatives.

Superior construction

Each pipe section is carefully assembled with a self-oxidizing aluminum inner liner, Type 3003-H-12. Outer pipe is made of heavy-duty galvanized steel with .018 minimum gauge. U.L. listing file MH 6512-volume 1. Diameters to 60" available on special order. Stainless steel liners also available. Apply to General Products for prices and lead times.

Type "B" gas vent UL 441 listed and tested to 470° F. maximum temperature, 1" clearance to combustibles.



Large inventories

For all sizes of venting systems, Air-Jet maintains complete stocks at the plant and in a network of warehouses. Locations are strategically chosen across the country to insure the fastest delivery and service in the industry.



Engineering services

Long an industry leader in technology, Air-Jet carries on a full program of research and testing for improved design and solution of venting problems.

Air-Jet's engineering staff is prepared to assist you with design services and advice on particular applications. For this customer service, you are invited to contact a nearby Air-Jet representative/distributor, or the Director of Engineering at our headquarters in Fredericksburg, Virginia.



Snap-lock speed

For faster installing, Air-Jet gives you "Snap-Lock" assembly. No twisting, no screws. **Just line up seams, slide one section into the other, and snap securely in place.** Joints are locked by an exclusive Air-Jet design. Easily unlocked by twisting counter-clockwise.



Rolled ends for extra strength

Male ends are fully rolled 360° to give added strength, overcome shipping or handling damage. Extra strong cartons, too—engineered from 200 lb. test board with four fold flap top. Other outstanding features: both round and oval sections available... leak-proof base flashing... true diameter... complete line 3" through 24" in stock, through 48" on special order.



Wind-tested and UL listed Installation Recommendations

Type B Gas Vent Jet Cap 3" through 12"

Air-Jet Vent Caps have the "Wind" symbol embossed on top to show wind testing according to UL standards.

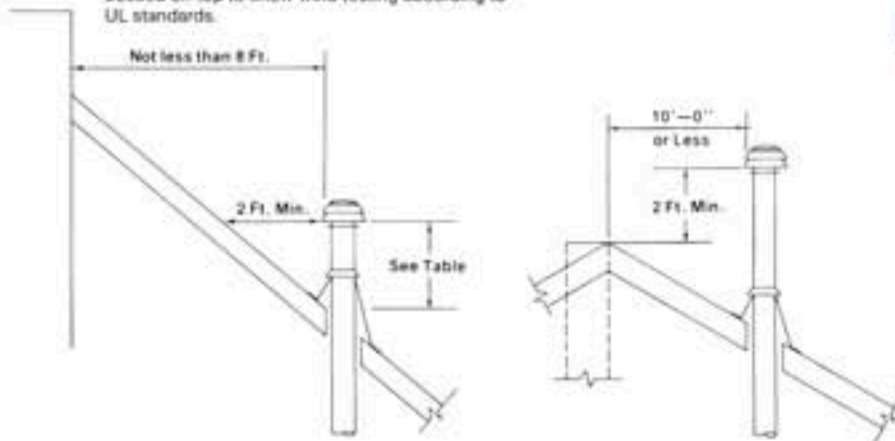

Roof Pitch	Minimum Height from Roof to Lowest Discharge Opening, Ft.
Flat to 7/12	1.0
Over 7/12 to 8/12	1.5
Over 8/12 to 9/12	2.0
Over 9/12 to 10/12	2.5
Over 10/12 to 11/12	3.25
Over 11/12 to 12/12	4.0

Fig. 1 — This cap is suitable for installation on listed gas vents terminating a sufficient distance from the roof so that no discharge opening is less than 2 feet horizontally from the roof surface, and the lowest discharge opening will be no closer than the minimum height specified, provided that the vent is not less than 8 feet from any vertical wall.

Fig. 2 — For installations other than covered by the table, or closer than 8 feet to any vertical wall, the cap shall be not less than 2 feet above the highest point where the vent passes through the roof and at least 2 feet higher than any portion of a building within 10 feet.

Snap-lock decorative housing



Features:

- All parts of housing package in contact with the flue gases made of high grade stainless steel to resist corrosion.
- Snap-Lock weather-proof design.
- Side panels finished inside and out with high temperature baked enamel.

Simplest housing assembly on the market. Only 8 parts—entire unit can be assembled on the ground, attached to roof by one man! Compact package contains everything you need in one carton. UL approved for use with gas. Rancher top of high grade stainless steel guards against birds, leaves and weather. Housing measures 17" X 17". Available in brick pattern or plain. (All housings available in 3', 4', 5', or 6' heights.)

Termination cap



Bird-proof louvered cap looks great on homes, garden apartments or commercial installations. Keeps out rain, snow, down drafts. Diameters—3" through 12"

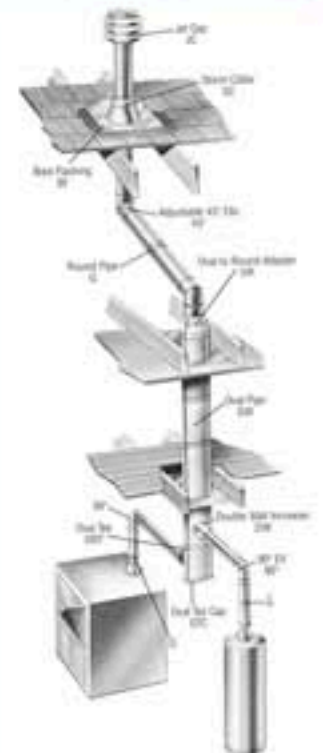

AIR-JET Installation Showing Various Items

How to specify Air-Jet Type B gas venting systems SAMPLE SPECIFICATION

The gas vent system shall be so engineered and constructed as to develop a positive flow adequate to exhaust all flue gases to outside atmosphere, without condensation within the vent and without spillage at any appliance draft hood. The system shall be sized in accordance with the Gas Vent Capacity Tables.

All flue-gas carrying parts of the vent system shall be Air-Jet

Type B double-wall gas vent piping and such piping shall be continuous from the appliances' outlets into the Air-Jet vent top or housing.

Air-Jet gas vent piping shall be installed in full compliance with the terms of its Underwriters' Laboratories, Inc. listing, with the manufacturer's installation instructions, and with nationally recognized good practice for such installations.

Multiple appliance vent systems (Courtesy of Gas Vent Institute)

VENT CONNECTOR TABLE

LEAST TOTAL HEIGHT	CONNECTOR RISE	MAXIMUM INPUT TO VENT CONNECTOR, Thousands of BTU Per Hour													
		VENT SIZE, INCHES													
		3"	4"	5"	6"	7"	8"	10"	12"	14"	16"	18"	20"	22"	24"
5'	1'	25	44	70	101	137	180	280	404	550	725	917	1135	1372	1635
	2'	30	53	83	120	162	213	333	480	626	817	1035	1277	1545	1840
	3'	33	60	93	135	183	240	375	540	730	950	1175	1450	1755	2090
6'	1'	26	46	72	104	142	185	289	416	577	755	955	1180	1425	1700
	2'	31	55	86	124	168	220	345	496	653	853	1080	1335	1610	1920
	3'	35	62	96	139	189	248	386	556	740	967	1225	1510	1830	2180
8'	1'	27	48	76	109	148	194	303	439	610	805	1015	1255	1520	1810
	2'	32	57	90	129	175	230	358	516	696	910	1150	1420	1720	2050
	3'	36	64	101	145	198	258	402	580	790	1030	1305	1610	1950	2320
10'	1'	28	50	78	113	154	200	314	452	642	840	1060	1310	1585	1890
	2'	33	59	93	134	182	238	372	536	730	955	1215	1490	1800	2150
	3'	37	67	104	150	205	268	417	600	827	1080	1370	1690	2040	2430
15'	1'	30	53	83	120	163	214	333	480	697	910	1150	1420	1720	2050
	2'	35	63	99	142	193	253	394	568	790	1030	1305	1610	1950	2320
	3'	40	71	111	160	218	286	444	640	898	1175	1485	1835	2220	2640
20'	1'	31	56	87	125	171	224	347	500	740	965	1225	1510	1830	2190
	2'	37	66	104	149	202	265	414	596	840	1095	1385	1710	2070	2470
	3'	42	74	116	168	228	300	466	672	952	1245	1575	1945	2350	2800
30'	1'	33	59	93	134	182	238	372	536	805	1050	1330	1645	1990	2370
	2'	39	70	110	158	215	282	439	632	910	1190	1500	1855	2240	2670
	3'	44	79	124	178	242	317	494	712	1035	1350	1710	2110	2550	3040
40'	1'	35	62	97	140	190	248	389	560	850	1110	1405	1735	2100	2500
	2'	41	73	115	166	225	295	461	665	964	1260	1590	1965	2380	2830
	3'	46	83	129	187	253	331	520	748	1100	1435	1820	2240	2710	3230
60'	1'	37	66	104	150	204	266	417	600	926	1210	1530	1890	2280	2720
	2'	44	79	123	178	242	316	494	712	1050	1370	1740	2150	2590	3090
	3'	50	89	138	200	272	355	555	800	1198	1565	1980	2450	2960	3520

COMMON VENT TABLE

LEAST TOTAL HEIGHT	VENT TYPE	MAXIMUM COMBINED INPUT TO EACH SECTION OF COMMON VENT, Thousands of BTU Per Hr.													
		VENT SIZE, INCHES													
		3"	4"	5"	6"	7"	8"	10"	12"	14"	16"	18"	20"	22"	24"
5'	L	—	48	76	109	149	195	310	455	630	830	1060	1330	1600	1920
	V	—	60	95	137	186	242	383	548	752	982	1240	1530	1815	2205
6'	L	—	52	82	117	160	210	325	468	708	925	1170	1445	1680	2080
	V	—	65	103	147	200	260	410	588	815	1065	1345	1660	1970	2390
8'	L	—	58	91	130	178	230	365	520	793	1035	1310	1620	1920	2330
	V	—	73	114	163	223	290	465	652	912	1190	1510	1860	2200	2680
10'	L	—	63	98	142	193	250	395	568	865	1130	1430	1765	2090	2540
	V	—	79	124	178	242	315	495	712	995	1300	1645	2030	2400	2920
15'	L	—	73	114	164	224	290	460	656	1008	1315	1665	2060	2430	2960
	V	—	91	144	206	280	365	565	825	1158	1510	1910	2360	2790	3400
20'	L	—	81	127	182	250	325	510	726	1126	1470	1860	2300	2720	3310
	V	—	102	160	229	310	405	640	916	1290	1690	2140	2640	3120	3800
30'	L	—	94	147	211	290	375	590	844	1327	1735	2190	2710	3210	3900
	V	—	118	185	266	360	470	740	1025	1525	1990	2520	3110	3680	4480
40'	L	—	105	164	236	320	420	660	945	1492	1950	2470	3050	3610	4390
	V	—	131	203	295	405	525	820	1180	1715	2240	2830	3500	4150	5050
60'	L	—	—	178	259	352	460	720	1100	1750	2280	2890	3570	4230	5050
	V	—	—	224	324	440	575	900	1380	2010	2620	3320	4100	4850	5900
80'	L	—	—	—	275	374	488	765	1232	1950	2550	3230	3980	4720	5750
	V	—	—	—	344	468	610	955	1540	2250	2930	3710	4590	5420	6600
100'	L	—	—	—	—	383	500	780	1335	2140	2790	3530	4360	5160	6290
	V	—	—	—	—	479	625	975	1670	2450	3200	4050	5000	5920	7200

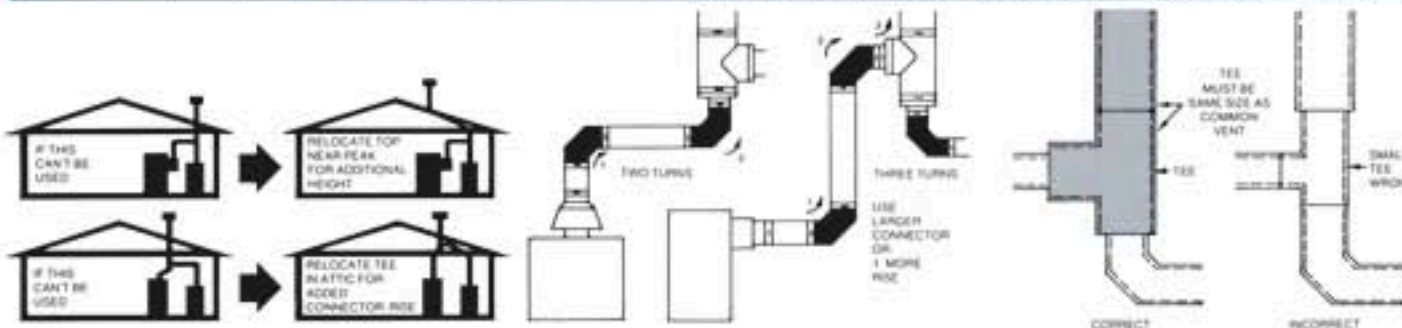

Round pipe and fittings 3"–12"



Round Pipe



Adjustable Pipe



45° Adjustable Ell



90° Adjustable Ell



90° Adjustable Ell As Offset



Round Tee

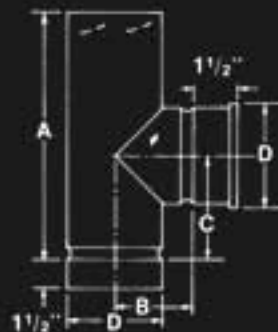

Round Pipe

Aluminum Inside Diameter listed
Galvanized Outside Diameter = Vent Size (D) plus 3/4"
Typical Catalog No. 4G5 = 4" dia. gas vent 5 ft. long

Round Pipe Sizes	A
G1—1' length—3" thru 8"	12"
G2—2' length—3" thru 12"	24"
G3—3' length—3" thru 12"	36"
G5—5' length—3" thru 7"	60"

Adjustable Pipe Sizes	A	Usable Length	
		Min.	Max.
3"–8" AR1/2	6"	2-3/8"	5"
10"–12" AR1	12"	2-3/8"	10-1/2"

45° Adjustable Ell

45° Adjustable Ell Sizes	A	B	D
3"–45°	2-1/2"	2-3/8"	3-3/8"
4"–45°	2-3/8"	3-3/8"	4-3/8"
5"–45°	2-3/8"	3-3/4"	5"
6"–45°	2-3/8"	3-3/4"	6-3/8"
7"–45°	3"	4"	7-3/8"
8"–45°	3-3/8"	3-3/4"	8-3/8"
10"–45°	3-3/8"	4-1/2"	10-3/8"
12"–45°	4-3/8"	4-1/2"	12-3/8"

90° Adjustable Ell

90° Adjustable Ell Sizes	A	B	D
3"–90°	5-3/8"	5-3/8"	3-3/4"
4"–90°	6-3/8"	6-3/8"	4-3/8"
5"–90°	6-3/8"	6-3/8"	5-3/8"
6"–90°	7"	6-3/8"	6-3/8"
7"–90°	7-3/8"	6-3/8"	7-3/8"
8"–90°	8-3/8"	7-3/8"	8-3/8"

90° Adjustable Ell As Offset

90° Adjustable Ell As Offset Sizes	A	B	D
3"	8-1/8"	2-3/8"	3-3/8"
4"	9-3/8"	2-3/8"	4-3/8"
5"	12"	2-3/8"	5-3/8"
6"	10-3/8"	2-3/8"	6-3/8"
7"	11-3/8"	3-3/8"	7-3/8"
8"	12-3/8"	3-3/8"	8-3/8"

Round Tee

Round Tee Sizes	A	B	C	D
4RT	9"	3-3/8"	4-1/8"	4-3/8"
5RT	10-3/8"	4-3/8"	5-3/8"	5-3/8"
6RT	11"	4-3/8"	5-3/8"	6-3/8"
7RT	12"	5-3/8"	6-3/8"	7-3/8"
8RT	13-3/8"	5-3/8"	6-3/8"	8-3/8"
10RT	14"	6-3/8"	6-3/8"	10"
12RT	17-3/8"	8-3/8"	8-3/8"	12-3/8"



Round Tee Cap



Jet Cap



Storm Collar



Adjustable Boot Flashing



Tall Cone Boot Flashing
(Soldered Tall Cone Flashings available on special order.)



Base Assembly

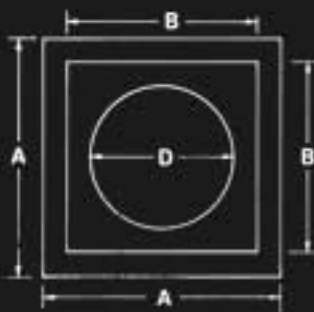
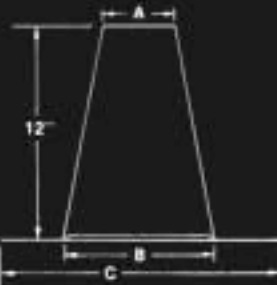
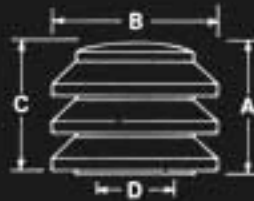

Round Tee Cap

Round Tee Cap Sizes	D
4RTC	4 1/2"
5RTC	5 1/2"
6RTC	6 1/2"
7RTC	7 1/2"
8RTC	8 1/2"
10RTC	10 1/2"
12RTC	12 1/2"

Jet Cap

(Bird Proof) C : from top of vent to top of jet cap

Jet Cap Sizes	A	B	C	D
3JC	4 1/2"	6 1/2"	4 1/2"	3 1/2"
4JC	4 7/8"	6 1/2"	4 3/4"	4 1/2"
5JC	5 1/8"	10 1/2"	5 1/4"	5 1/2"
6JC	7 1/8"	10 1/2"	7 1/4"	6 1/2"
7JC	7 3/8"	10 1/2"	7 1/4"	7 1/2"
8JC	9 1/8"	10 1/2"	9 1/4"	8 1/2"
10JC	10 1/8"	15"	8 3/4"	10 3/4"
12JC	13 1/8"	15"	11 1/4"	12 3/4"

Storm Collar

D-Dimension = Vent Size plus 3/4"

Adjustable Boot Flashing

Note: Boot flashing adjusts from flat to 6/12 pitch. Special flashings available—order as follows: BFX 7/12—12/12 pitch; BFY 13/12—18/12 pitch; BFZ 19/12—24/12 pitch.

Adjustable Boot Flashing Sizes	A	B
3BF	5 1/2"	8 3/8"
4BF	4 3/4"	8 3/8"
5BF	5 1/2"	10 1/2"
6BF	5"	10 1/2"
7BF	6 1/4"	13 1/2"
8BF	6"	13 1/2"
10BF	8 1/2"	14 1/2"
12BF	8 1/2"	16 1/2"

Tall Cone Boot Flashing

Tall Cone Boot Flashing Sizes	A	B	C so.
3BFT	3 1/4"	8 3/8"	15 1/2"
4BFT	4 1/4"	8 3/8"	15 1/2"
5BFT	5 1/4"	8 3/8"	15 1/2"
6BFT	6 1/4"	10 1/2"	18 1/2"
7BFT	7 1/4"	10 1/2"	18 1/2"
8BFT	8 1/4"	10 1/2"	18 1/2"
10BFT	10 1/4"	13 1/2"	21 1/2"
12BFT	12 1/4"	14 1/2"	24 1/2"

Base Assembly

Base Assembly Sizes	A	B	D
4BA	10 1/2"	6 3/4"	4"
5BA	10 1/2"	7 3/4"	5"
6BA	10 1/2"	8 3/4"	6"
7BA	11 1/4"	9 3/4"	7"
8BA	12 1/4"	10 3/4"	8"
10BA	15 1/4"	13 3/4"	10 3/4"
12BA	17 1/4"	15 3/4"	12 3/4"

Single appliance vent systems (Courtesy of Gas Vent Institute)

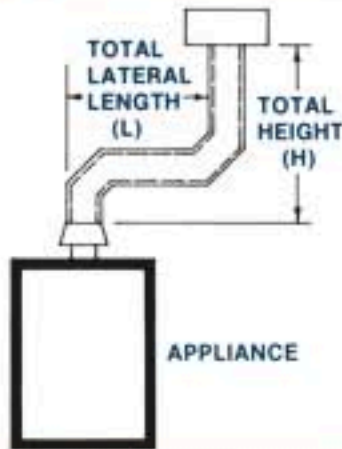

Example: Appliance has an input of 150,000 BTUH, 6-inch draft hood, vent height of 20 feet, lateral of 10 feet. Using

the table, a 5-inch vent size is adequate because the total height exceeds 10 feet.

TOTAL VENT HEIGHT H	LENGTH OF LATERAL L	MAXIMUM CAPACITY, THOUSANDS OF BTUH VENT SIZE, INCHES		
		3"	4"	5"
20'	0	61	119	202
	2'	51	100	166
	10'	44	89	150
	20'	35	78	134
	30'	—	68	120

TOTAL VENT HEIGHT H	LENGTH OF LATERAL L	MAXIMUM CAPACITY, Thousands of BTU Per Hour*													
		VENT SIZE, INCHES													
		3"	4"	5"	6"	7"	8"	10"	12"	14"	16"	18"	20"	22"	24"
5'	0	45	83	133	192	265	345	535	785	1070	1405	1795	2215	2690	3210
	2'	33	62	99	147	203	267	415	600	815	1065	1350	1685	2025	2425
	5'	31	59	95	140	195	258	407	590	800	1050	1340	1665	2015	2420
	10'	28	53	90	131	182	243	390	560	770	1020	1310	1650	1995	2380
6'	0	46	86	141	205	285	370	570	850	1170	1530	1960	2430	2950	3520
	2'	36	67	105	157	217	285	455	650	890	1170	1480	1850	2220	2670
	6'	32	61	100	149	205	273	435	630	870	1150	1470	1820	2210	2650
	12'	28	55	91	137	190	255	406	610	840	1110	1430	1795	2180	2600
8'	0	50	94	155	235	320	415	660	970	1320	1740	2220	2750	3360	4010
	2'	40	75	120	180	247	322	515	745	1020	1340	1700	2110	2560	3050
	8'	35	66	109	165	227	303	490	720	1000	1320	1670	2070	2530	3030
	16'	28	58	96	148	206	281	458	685	950	1260	1600	2035	2470	2960
10'	0	53	100	166	255	345	450	720	1060	1450	1925	2450	3050	3710	4450
	2'	42	81	129	195	273	355	560	850	1130	1480	1890	2340	2840	3390
	10'	36	70	115	175	245	330	525	795	1080	1430	1840	2280	2780	3340
	20'	—	60	100	154	217	300	486	735	1030	1360	1780	2230	2720	3250
15'	0	58	112	187	285	390	525	840	1240	1720	2270	2900	3620	4410	5300
	2'	48	93	150	225	316	414	675	985	1350	1770	2260	2800	3410	4080
	15'	37	76	128	198	275	373	610	905	1250	1675	2150	2700	3300	3980
	30'	—	60	107	169	243	328	553	845	1180	1550	2050	2620	3210	3840
20'	0	61	119	202	307	430	575	930	1350	1900	2520	3250	4060	4980	6000
	2'	51	100	166	249	346	470	755	1100	1520	2000	2570	3200	3910	4700
	10'	44	89	150	228	321	443	710	1045	1460	1940	2500	3130	3830	4600
	20'	35	78	134	206	295	410	665	990	1390	1880	2430	3050	3760	4550
30'	—	68	120	186	273	380	626	945	1270	1700	2330	2980	3650	4390	
30'	0	64	128	220	336	475	650	1060	1550	2170	2920	3770	4750	5850	7060
	2'	56	112	185	280	394	535	865	1310	1800	2380	3050	3810	4650	5600
	20'	—	90	154	237	343	473	784	1185	1650	2200	2870	3650	4480	5310
	40'	—	—	—	200	298	415	705	1075	1520	2060	2700	3480	4270	5140
40'	0	66	132	228	353	500	685	1140	1730	2400	3230	4180	5270	6500	7860
	2'	59	118	198	298	420	579	960	1420	2000	2660	3420	4300	5260	6320
	20'	—	96	167	261	377	516	860	1310	1830	2460	3200	4050	5000	6070
	40'	—	—	—	223	333	460	785	1205	1710	2310	3020	3840	4780	5820
60'	0	—	136	236	373	535	730	1250	1920	2700	3650	4740	6000	7380	9000
	2'	—	125	213	330	470	650	1060	1605	2250	3020	3920	4960	6130	7400
	30'	—	—	170	275	397	555	930	1440	2050	2780	3640	4700	5730	7000
	60'	—	—	—	—	334	475	830	1285	1870	2560	3380	4330	5420	6660
80'	0	—	—	239	384	550	755	1290	2020	2880	3900	5100	6450	8000	9750
	2'	—	—	217	350	495	683	1145	1740	2460	3320	4310	5450	6740	8200
	40'	—	—	—	275	404	570	980	1515	2180	2980	3920	5000	6270	7650
	80'	—	—	—	—	—	—	850	1420	2000	2750	3640	4680	5850	7200
100'	0	—	—	—	400	560	770	1310	2050	2950	4050	5300	6700	8600	10,300
	2'	—	—	—	375	510	700	1170	1820	2550	3500	4600	5800	7200	8800
	50'	—	—	—	—	405	575	1000	1550	2250	3100	4050	5300	6600	8100
	100'	—	—	—	—	—	—	870	1430	2050	2850	3750	4900	6100	7500

NOTES: A. "*" Read across to the column which shows a capacity equal to or greater than the appliance nameplate BTUH input.
 B. "—" Where no capacity is given, vent may be liable to both spillage and condensation.

C. Regardless of altitude, always design vent for sea level nameplate appliance input.
 D. "0" lateral applies only to a vertical vent attached to a top outlet draft hood.



Oval Pipe



Standard Oval 45° Ell



Flat Oval 45° Ell



Oval-Round Tee



Oval Tee Cap



Oval Jet Cap



Oval Storm Collar



Oval Boot Flashing



Oval to Round Adapter



Round to Oval Adapter



Oval Fire Stop Spacer

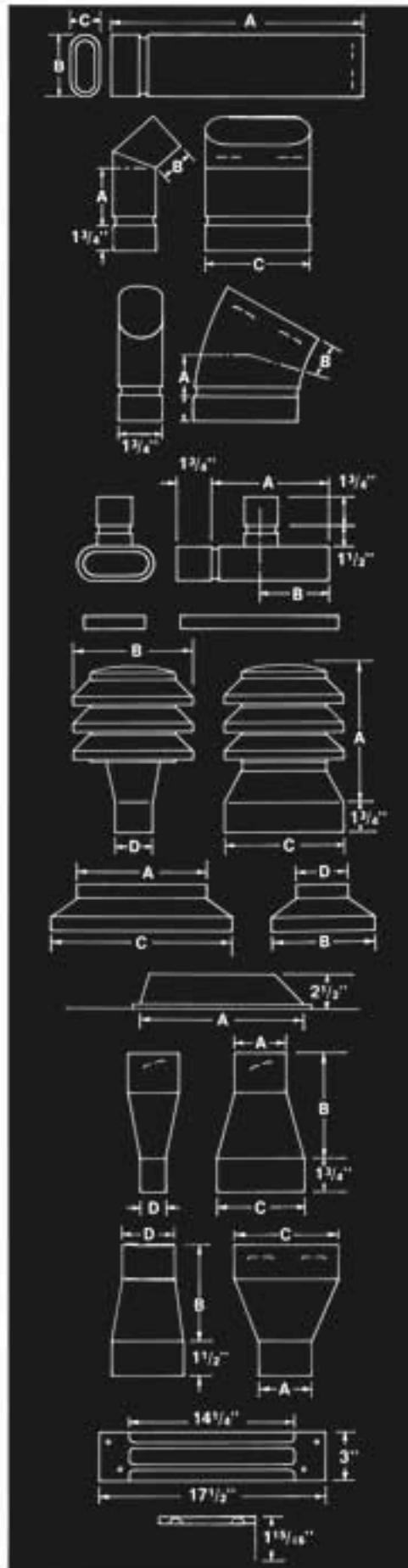

Oval Pipe

Oval Pipe Sizes	A	B	C
4/GW2	24"	7 1/8"	2 3/4"
4/GW5	60"	7 1/8"	2 3/4"
5/6GW1	12"	10 5/8"	3 1/2"
5/6GW2	24"	10 5/8"	3 1/2"
5/6GW3	36"	10 5/8"	3 1/2"
5/6GW5	60"	10 5/8"	3 1/2"

Standard Oval 45° Ell

Standard Oval 45° Ell Sizes	A	B	C
4/O45	2 1/2"	3 1/4"	2 1/2"
5/6O45	2 1/2"	3 1/4"	10 1/2"

Flat Oval 45° Ell

Flat Oval 45° Ell Sizes	A	B
5/6OF45	5"	6 1/2"

Oval-Round Tee

Oval-Round Tee Sizes	A	B
5/6ORT	12"	6 1/8"

Oval Tee Cap

Oval Tee Cap Sizes 5" / 6" —OTC

Oval Jet Cap

Oval Jet Cap Sizes	A	B	C	D
4/OJC	9 3/4"	6 1/2"	7 1/2"	2 1/4"
5/6OJC	13 3/4"	10 1/2"	10 1/2"	3 1/2"

Oval Storm Collar

Oval Storm Collar Sizes	A	B	C	D
4/OSC	9 3/4"	4 1/4"	7 1/2"	2 1/4"
5/6OSC	10 1/2"	5 1/4"	12 3/4"	3 1/2"

Oval Boot Flashing

Oval Boot Flashing Sizes	A
4/OBF	16"
5/6OBF	18"

Oval to Round Adapter

Oval to Round Adapter Sizes	A	B	C	D
4/OR	4 1/2"	6 1/2"	7 1/2"	2 1/2"
5/6O5R	5 1/2"	7 1/2"	10 1/2"	3 1/2"
5/6O6R	6 1/2"	7 1/2"	10 1/2"	3 1/2"

Round to Oval Adapter

Round to Oval Adapter Sizes	A	B	C	D
5/6RO	6 1/2"	7 1/2"	10 1/2"	3 1/2"

Oval Fire Stop Spacer 40FS—5/60FS

40FS (To be used in 2X4 stud spacing)
5/6OF (To be used in 2X6 stud spacing)



Wall Thimble

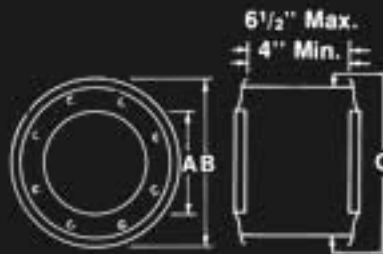

Draft Hood Connector



Double Wall Inserter

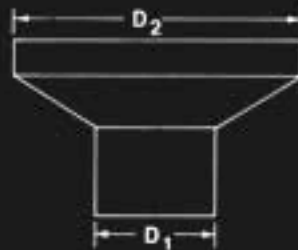

Pipe Collar

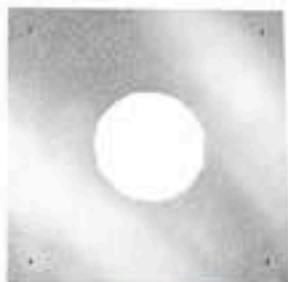

Fire Stop



Wall Thimble

Wall Thimble Sizes	A	B	C
3VT	3 1/4"	6 3/4"	5 1/4"
4VT	4 1/4"	9 3/4"	8 1/2"
5VT	5 1/4"	9 3/4"	8 1/2"
6VT	6 1/4"	10 3/4"	9 1/2"
7VT	7 1/4"	12 1/2"	11 1/2"
8VT	8 1/4"	12 1/2"	11 1/2"

Draft Hood Connector

Note: Aluminum extension can be formed to fit oval draft hood outlets of furnaces. Larger sizes available on special order.

Draft Hood Connector Sizes	D
3DHC	3 1/2"
4DHC	4 1/2"
5DHC	5 1/2"
6DHC	6 1/2"
7DHC	7 1/2"
8DHC	8 1/2"

Double Wall Inserter

Length: 1 1/4" plus 1/4" for each size difference between D₁ and D₂

D₁ x D₂

3" x 4" through 7" x 8"

Also:

8" x 10", 8" x 12", 10" x 12"

Pipe Collar

3PC—6PC: A: 9 1/4"

7PC: A: 10 1/4"

Fire Stop

3GF—8GF: A: 12 1/2"

10GF and 12 GF: A: 19 1/4"



Round Pipe



45° Elbows



Round Tee



Round Tee Cap



Jet Cap

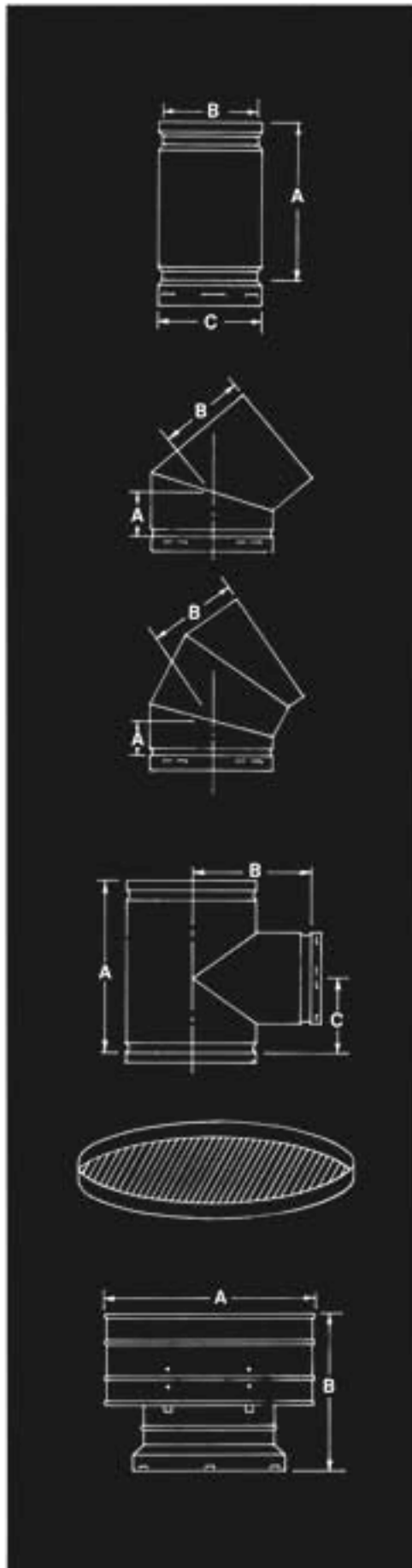

Round Pipe

Note: Adjustable length available from 6" to 18"

Round Pipe Sizes	A	B	C
14G2 or 3	24" or 36"	14"	15"
16G2 or 3	24" or 36"	16"	17"
18G2 or 3	24" or 36"	18"	19"
20G2 or 3	24" or 36"	20"	21"
22G2 or 3	24" or 36"	22"	23"
24G2 or 3	24" or 36"	24"	25"

45° Elbows

Elbow Sizes	A	B
14—45°	5"	6"
16—45°	5½"	6½"

Elbow Sizes	A	B
18—45°	6"	6¾"
20—45°	7¾"	6¾"
22—45°	7¾"	6¾"
24—45°	8¾"	7"

Draft Hood Connectors Available on Special Order.

Round Tee

Cat. No.	A	B	C
14RT	24"	9½"	9"
16RT	24"	10½"	10"
18RT	27"	11½"	11"
20RT	36"	12½"	13"
22RT	36"	13½"	14"
24RT	36"	14½"	15"

Round Tee Cap Cat No.

14RTC	20RTC
16RTC	22RTC
18RTC	24RTC

Jet Cap

Jet Cap Sizes	A	B
14JC	28"	20¼"
16JC	32"	23"
18JC	36"	25¼"
20JC	40"	28¾"
22JC	44"	31¾"
24JC	48"	33¾"

-24" for industrial installations



Storm Collar



Adjustable Boot Flashing



Tall Cone Boot Flashing

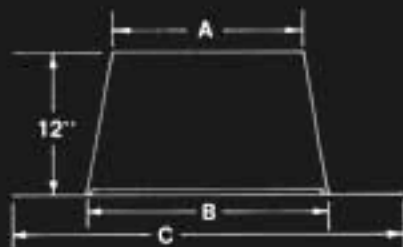

Base Assembly

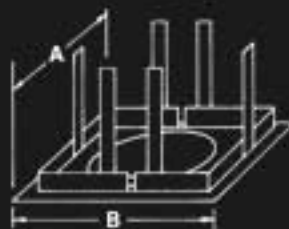

Double Wall Inserter



Storm Collar

Storm Collar Sizes	A	B
14SC	15"	4"
16SC	17"	4 1/2"
18SC	19"	5"
20SC	21"	6"
22SC	23"	7"
24SC	25"	8"

Adjustable Boot Flashing

Boot Flashing Sizes	A
14BF	5"
16BF	5 1/2"
18BF	6"
20BF	6 1/2"
22BF	7"
24BF	7 1/2"

Note: Boot flashing adjusts from flat to 5/12 pitch. Adjustable flashing may be ordered for 6/12 to 10/12 pitch.

Tall Cone Boot Flashing

Tall Cone Boot Flashing (Soldered)			
Sizes	A	B	C so.
14BFT	15 1/2"	16 1/4"	24 1/2"
16BFT	17 1/2"	18 3/4"	26 1/4"
18BFT	19 1/2"	20 1/4"	28 3/4"
20BFT	21 1/2"	22 3/4"	30 3/4"
22BFT	23 1/2"	24 3/4"	32 3/4"
24BFT	25 1/2"	26"	34"

Base Assembly

Support Sizes	A	B
14BA	17"	19"
16BA	19"	21"
18BA	21"	23"
20BA	23"	25"
22BA	25"	27"
24BA	27"	29"

Double Wall Inserter

_____ x 14"	_____ x 20"
_____ x 16"	_____ x 22"
_____ x 18"	_____ x 24"



Get the best. Get Air-Jet products, know-how, service.

Cut your time and labor costs with Air-Jet advantages. Engineered for faster installing, top performance. Quality control from long experience. Highly-trained representatives to help

solve your problems. Full range of systems, strategically warehoused for quick delivery. For prompt service, contact a nearby representative, or call us.

10MHP 0205

AIRJET

3000 MINE ROAD FREDERICKSBURG, VA 22408
PHONE: 866-324-7538 FAX: 574-262-2075