

LISTED METHODS OF ATTACHING AIRJET "B" VENT PIPE TO FEMALE END (INLET END-DOWN) OF OTHER LISTED MANUFACTURERS VENT PIPE USING AIRJET FEMALE UNIVERSAL ADAPTER (3"-8")

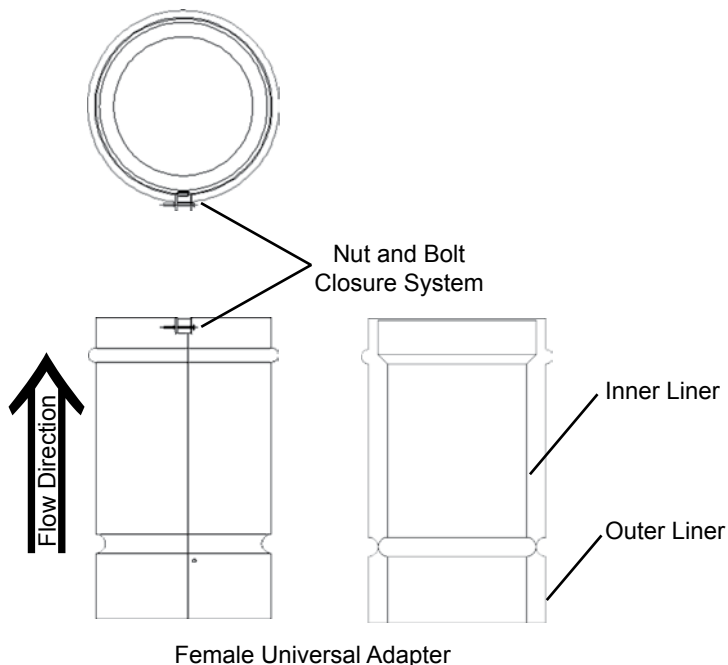

AirJet Type "B" Vent may be connected to Type "B" Vent pipe or fittings manufactured by the companies listed on reverse side, utilizing the specific methods and AirJet fittings shown.

1. To connect AirJet pipe to the female end of other listed manufacturer's pipe or fittings a 3" - 8" Female Universal Adapter (FUA) must be used. The aluminum liner of the FUA should be installed to the outside of the aluminum liner of the non AirJet Vent. The galvanized outer pipe of the FUA should be installed to the outside of the outer pipe of the non AirJet Vent. (see the enlarged view of the typical joint)
2. Open the nut and bolt closure system far enough so that the outside shell of the FUA fits around the outside of the pipe on the female end of the other product.
3. From the bottom of the FUA reach in and center the interior liner of the adapter around the aluminum liner of the other product.
4. At this point slide the fitting up to the lock stop on the other product. Tighten the nut and bolt closure securely for a positive joint. You may now use the standard AirJet "B" Vent Locking System and instructions below this point.

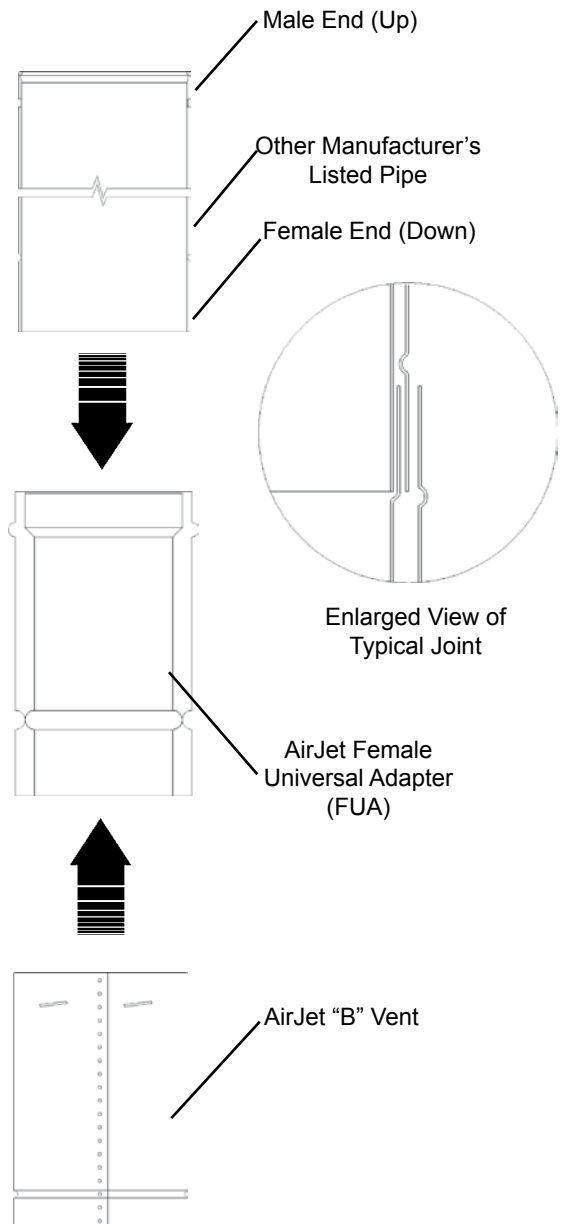

LISTED METHODS OF ATTACHING AIRJET "B" VENT PIPE TO MALE END (OUTLET END-UP) OF THE OTHER LISTED MANUFACTURERS.



Either of the following Methods are acceptable and are UL Listed.

METHOD 1:

Using an AirJet Type "B" Vent AR1/2 fitting. (see Figure 1)

1. Open nut and bolt closure far enough so that the outside galvanized shell fits over and around the outside of the other manufacturer's male end fitting.
2. Slide the fitting down, the interior liner of the AR1/2 will fit inside the other pipe for a "correct drip" installation.
3. Continue to slide the fitting down until it stops, or there is at least 1 1/4" of engagement.
4. Secure the outside nut and bolt closure for a positive joint.
5. You may now continue running AirJet "B" Vent from the AR1/2 above this joint using AirJet "B" Vent.

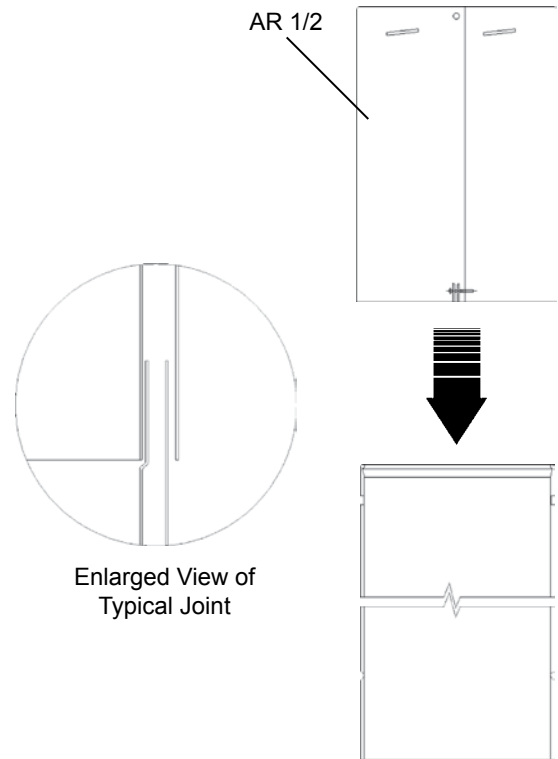

Figure 1

METHOD 2:

Using an AirJet Type "B" Vent Pipe Female End. (see Figure 2)

1. AirJet inner and outer liners are sized so that the female end of AirJet pipe will fit over other manufacturer's male end fitting.
2. Slide the AirJet pipe down to the stop. The outer galvanized shell will fit over and around the outside of the other pipe, and the inside liner will fit on the inside.
3. Secure the connection with three (3) evenly spaced self-tapping sheet metal screws.

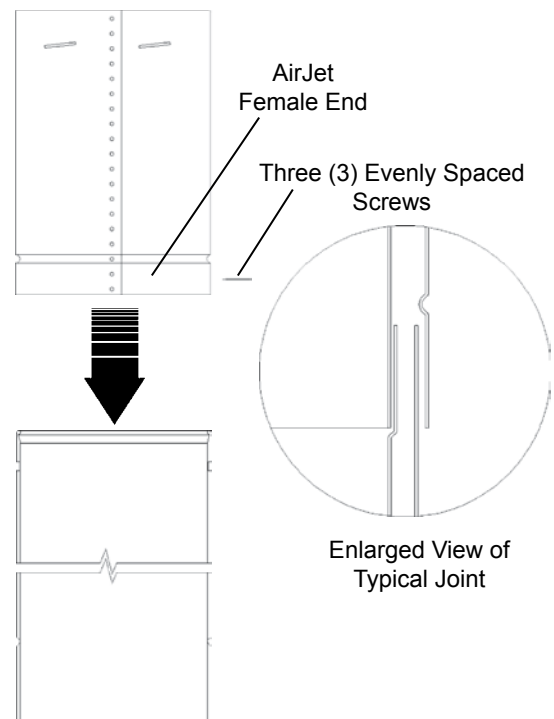

Figure 2

OTHER LISTED MANUFACTURERS
OF 3"-8" TYPE "B" VENT

American Metal Products - Hart & Cooley - Metal Fab Inc. - Mitchell
Metal Products - Selkirk - Simpson Dura-vent Co. (3" - 6" Only)